



USA
KOBOLD Instruments Inc.
1801 Parkway View Drive
Pittsburgh, PA 15205
PH: 412-788-2830
FAX: 412-788-4890

Canada
KOBOLD Instruments
Canada, Inc.
9A Aviation
Pointe-Claire, QC H9R 4Z2
PH: 514-428-8899
Fax: 514-428-8899

Series DPM
Pelton Wheel Flow Sensor

www.kobold.com

Precautions

- **User's Responsibility for Safety:** KOBOLD manufactures a wide range of process sensors and technologies. While each of these technologies are designed to operate in a wide variety of applications, it is the user's responsibility to select a technology that is appropriate for the application, to install it properly, to perform tests of the installed system, and to maintain all components. The failure to do so could result in property damage or serious injury.
- **Proper Installation and Handling:** Use a proper sealant with all installations. Never overtighten the sensor within its fittings. Always check for leaks prior to system start-up.
- **Wiring and Electrical:** Because this is an electrically operated device, only properly trained personnel should install and maintain this product. Be sure that the power supplied to the flow sensor is appropriate for the electronics version supplied. Electrical wiring of the sensor should be performed in accordance with all applicable national, state and local codes.
- **Temperature and Pressure:** The DPM is designed for use in application temperatures from -10°F to 176°F. Operation outside these limitations will cause damage to the unit.
- **Infrared Technology:** This sensor employs a paddle wheel that breaks an infrared light beam as fluid flows through the sensor body. This means that only translucent fluids which will pass light can be metered by the DPM.
- **Material Compatibility:** The DPM process wetted parts for the various body materials are stated below. Make sure that the DPM's wetted materials are chemically compatible with the media. While the sensor's outer housing is liquid resistant when installed properly, it is not designed to be immersed. The device should be mounted in such a way that the external surfaces do not normally come into contact with fluid.
- **Flammable, Explosive and Hazardous Applications:** The DPM is not an explosion-proof design. It should not be used in applications where an explosion-proof design is required.
- **Make a Fail-Safe System:** Design a fail-safe system that accommodates the possibility of sensor or power failure. In critical applications, KOBOLD recommends the use of redundant backup systems and alarms in addition to the primary system.

**Electrical Connection for Output C30R & C34P
(w/5-wire M-12 Micro-DC plug)**

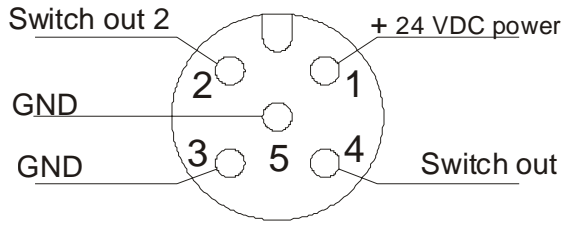

C30R

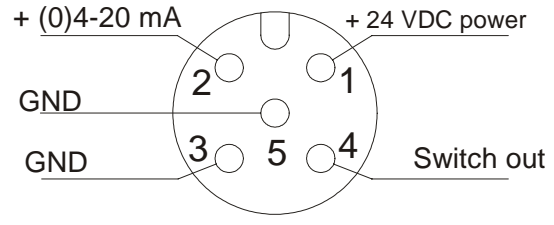

C34P

Micro-DC Cable Color Codes: Brown= Pin 1; White= Pin 2; Blue= Pin 3; Black= Pin 4; Gray= Pin 5

**Electrical Connection for Output F300 & F500
(3-wire Pulse Frequency Transmitters)**

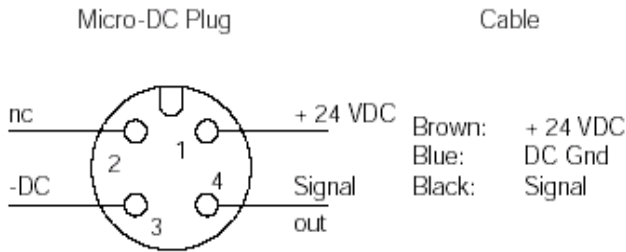

**Electrical Connection for Output L443
(3-wire 4-20 mA)**

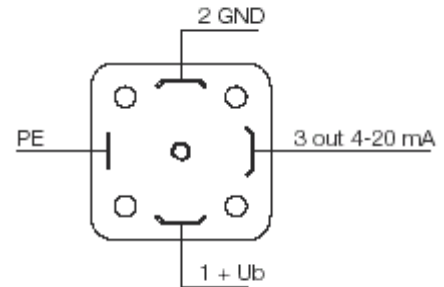

Micro-DC Cable Color Codes: Brown= Pin 1; White= Pin 2; Blue= Pin 3; Black= Pin 4

**Electrical Connection for Output L343
(3-wire, 4-20 mA Transmitter)**

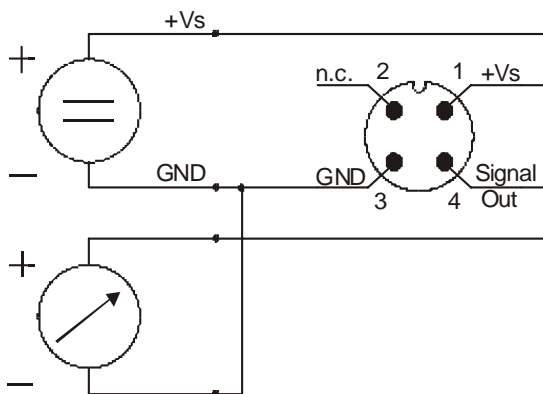

**Electrical Connection for Output Z340
(3-wire, 4-20 mA Transmitter)**

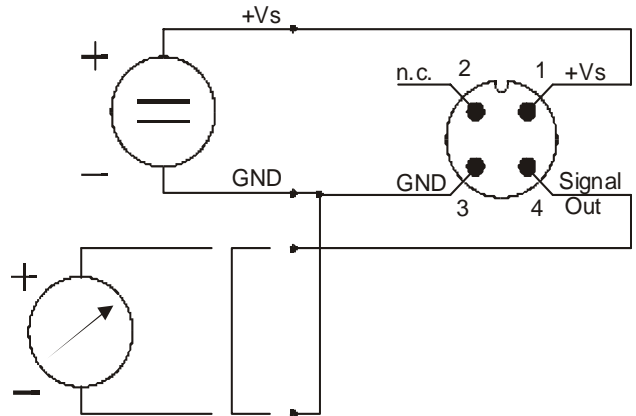

NOTE: If the output signal is not used, connect a jumper wire between pins 3 & 4 for the electronic indicator to function.

**Electrical Connection for Output K000
(OEM w/ 6 Ft Cable)**

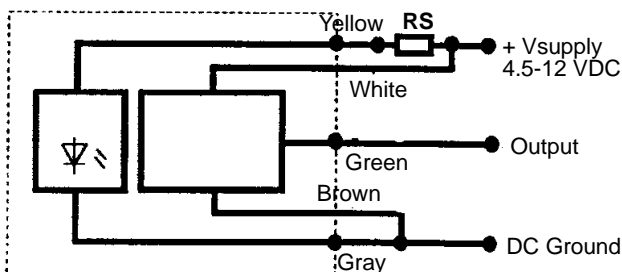

RS = User supplied, external current limiting resistor

To calculate the required resistor value (in Ohms):

$$RS \geq \frac{V_{supply} - 1.2}{0.015}$$

Part Number Decoding and Frequency at Max. Flow

Range GPH	Freq at f.s. (Hz)	Brass	Stainless Steel	Fitting	Output/Electronics
0.24 -11.1	228	DPM-1157	DPM-1557	N1=1/8" NPT N2=1/4" NPT	K000=NPN Freq Output, w/6 ft. PVC Cable F300=Frequency output, Micro-DC plug F500=Frequency output w/6 ft. PVC cable L343=4-20 mA, 3 wire, Micro-DC plug L443=4-20 mA, DIN 43650 plug C34P=Compact electronic, 4-20 mA w/ 1 PNP switch C30R=Compact electronic, 2 PNP switches Z340=Electronic Pointer Indicator w/4-20 mA, 3-wire output
0.8 - 15.0	217	DPM-1160	DPM-1560		
0.8 - 30.0	344	DPM-1170	DPM-1570		
0.8 - 48.0	372	DPM-1180	DPM-1580		
0.8 - 60.0	415	DPM-1190	DPM-1590		
0.8 - 80.0	439	DPM-1195	DPM-1595		
Accessories					
Part Number 807.037=Mating 4-pin Micro-DC plug with 6 ft. cable for output F300, L343, & Z340					
Part Number 807.007=Mating 5-pin Micro-DC plug with 6 ft. cable for output C34P, & C30R					

Mechanical Installation

Piping Preparation: Piping should be rigidly supported at both the inlet and outlet of the sensor to prevent potential damage due to excessive stress on the sensor fittings. The inlet flow is redirected via a nozzle, therefore no inlet or outlet straight piping is required and the sensor can be mounted in any orientation. With horizontal flow, we suggest that the sensor electronics be positioned at the 3 or 9 o'clock position to minimize the entrapment of air bubbles that can cause an erratic signal output.

Pumps: All pumps cause pulsations in the fluid. Centrifugal pumps cause the least amount of pulsations in the fluid and positive displacement or reciprocating pumps cause the most. In order to minimize the effect of these pulsations on sensor accuracy, the sensor should be located as far away from the pump as possible. A pulsation dampener or accumulator may be used to dampen pulsations if required. If the fluid pulsations cannot be reduced to an acceptable level, a field calibration to determine the new K-factor for the sensor installed in a pulsating system may be required.

Viscosity: All flow range and calibration data provided with this sensor are for water. All pelton wheel type transducers are affected by viscosity. Higher viscosities tend to make the pelton wheel turn slower for a given flow rate. This results in a lower K-factor for the sensor when it is used with a viscous media (i.e. viscosity > 10 cSt.) and the calibration data provided for water flow will no longer be valid. If the sensor is to be used with slightly viscous media, a field calibration is required to determine the new K-factor for the sensor.

Field calibration: For frequency output versions, a simple field calibration can be performed to determine the new K-factor for the sensor when it is to be used in a manner in which the above specified calibration information does not apply (i.e. use with viscous or pulsating media, insufficient straight run etc.). With the sensor installed in the system, dispense a known quantity of the fluid to be measured while using a pulse counter to count the number of pulses generated by the sensor during the dispense. This information can be used to determine the new K-factor specific to your system and fluid.

Specifications

Accuracy: ±1.5% of full scale

Wetted Parts

Brass Body: Nickel-plated Brass, 316SS, Polysulfone, Polypropylene, Sapphire, and Buna-N

St. Steel Body: 316 SS, Polysulfone, Polypropylene, Sapphire, and FKM

Max. Pressure: 230 PSIG

Temperature Range: -10°F to +176°F

Electrical (see model number table for model codes and descriptions for each output type)

Electrical Protection (all versions): NEMA 4X/IP 65

Outputs F300, F500, K000

F300: PNP open collector, 25mA max.
Power: 14-28 VDC, 4-pin plug

F500: PNP open collector, 25mA max.
Power: 14-28 VDC, 6 ft. cable

K000: OEM Version, NPN, 7 mA typical, 10 mA max.
Input Power: 4.5-12 VDC @ 15-25 mA
6 ft. PVC cable

Electrical (continued)

Output L343: 4-20 mA, 3-wire, R_{max} < 500 ohms, power= 24 VDC

Electrical Connector = 4 pin micro-DC plug, male

Output L443: 4-20 mA, 3-wire, R_{max} < 500 ohms, power= 24 VDC

Electrical Connector = DIN 43650 (Hirschmann®) plug

Output Type Z340

Indicator Housing: Aluminium, Polyamide

Display: Electronic, 240° display

Power supply: 24 VDC ±20%

Output: 4-20 mA, 3-wire, factory set

Max. Load: 250 Ohms

Electrical Connection: M-12 Micro-DC, 4-pin

Output Type C34P & C30R

Compact Electronics: 4-20 mA + 1 PNP switch or 2 PNP switches depending on model code

Power Supply: 24 VDC ±20%, 80 mA max.

Analog Output: 4-20 mA, 3-wire, R_{max} < 500 ohm

Switch Type: PNP open collector, 24 VDC, 300 mA max.

Electrical Connection: 5 pin micro-DC plug, male

(A separate instruction manual exists for programming and setup of the Compact Electronics Displays)