

OMR 700
PAPERLESS RECORDER





PAPERLESS RECORDER OMR 700

Modular data recorder with 8 positions for plug-in cards:

- analogue inputs, max. 12 inputs/module
- digital inputs, max. 12 inputs/module
- analogue outputs, max. 4 outputs/module
- digital outputs, max. 10 outputs/module
- data outputs

Basic features of the recorder:

- color TFT display 5,7" with a capacitive panel
- primary and backup system
- digital inputs and outputs
- record into internal memory, SD card or USB Flash
- Ethernet 10/100B, RS 485 – Modbus
- USB, microUSB
- internal data memory 2x 512 MB
- sound module
- RTC
- size 150 x 150 mm
- cover IP64
- power source 80...250 V AC/DC

INTRODUCING THE RECORDER

Company ORBIT MERRET launches a new product in its portfolio: Paperless recorder OMR 700.

This recorder is intended for technologies and workings where it is needed to display and/or record a number of electrical and nonelectrical values at one place. Universality, versatility and in particular good value for money predestine the recorder to fulfil most of your demanding needs including the IP64 front panel cover.

Our paperless recorder has been developed with versatility and intuitive control in mind. Thanks to its modularity the user can insert input or output cards into any of the 8 existing slots. Maximal configuration of the recorder thus allows to measure and record up to 96 inputs. In order to increase reliability, the recorder has two systems - primary and backup.

Always on board are digital control inputs and outputs, serial line RS 485, Ethernet 10/100, USB connector as well as 512 MB internal memory to record the measured data.

PROJECTION

Color 5,7" TFT display with fine resolution dominates the device. The display is multi-touch and it therefore allows an ease of use.

CONTROL

Recorder is controlled by both the touch screen and the push buttons with adjustable functions, positioned underneath a sliding front door.

Two LEDs indicate run/error and state of data recording.

SETTING

All functions and settings can be performed directly on the instrument's display in a clear graphical menu. For a more comfortable setting a USB keyboard or mouse can be connected.



DATA RECORDING

The OMR 700 can record measured data from any of its active inputs, nodes and mathematical functions. Data are stored in the internal 512 MB memory with compression that allows up to four-fold increase of its physical memory without slowing down. Data can also be stored on an external SD card or USB flash drive.

In case of a limited number of measuring inputs, measurement data can be stored with a period of up to 1 ms.

The records can be either in BIN or „CVS“ format. However, the latter is much more demanding on memory.

Recording speed according to number of channels / memory space

Recording speed	16 inputs	48 inputs	80 inputs	96 inputs
1 ms	2 hours	x	x	x
10 ms	20 hours	7,5 hours	x	x
1 s	2,5 months	1 month	16 days	13 days
1 min	13 years	5 years	2,5 years	2,2 years
10 min	132 years	52 years	26 years	22 years

MODULES

The development of the device has been performed with an increased emphasis on technical solutions and universality. Card design not only allows their use in any position of the recorder, but also their additional insertion into vacant slots. Thus, if new requirements to increase the number or type of inputs and outputs occur in the course of using the recorder, just order another card and insert it into a vacant slot. In this way the instrument can „grow“ in compliance with your requirements.

All analogue modules are fully isolated from the internal bus, and some cards have galvanic isolation even between individual channels.

Basic version of the recorder includes power supply module and communication module with Ethernet 10/100, RS 485 (ASCII, MODBUS), five digital inputs and two digital outputs.

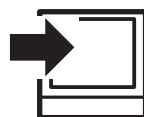

- 3x universal - DC, PM, OHM, RTD, Ni, Cu, T/C, DU
- 12x DC - voltage/current input
- 4x/5x RTD input - Pt xxx, Ni xxx, Cu xxx
- 4x T/C input - J/K/T/E/B/S/R/N/L
- 2x DMS - input for strain gauges
- 3x DC - precise voltage and current input
- 2x AC/PWR - voltage/current/power/frequency
- 12x digital input 10...250 V AC/DC
- 12x input counter/frequency
- 2x input Up/DW counter/frequency/IRC

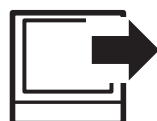

- 4x relay with switch-over contact
- 8x relay with switch-on contact
- 8x open collector NPN
- 16x open collector NPN
- 8x open collector PNP
- 6x SSR
- 2x/4x analogue output
- 1x PROFIBUS
- 1x PROFINET



PROJECTION

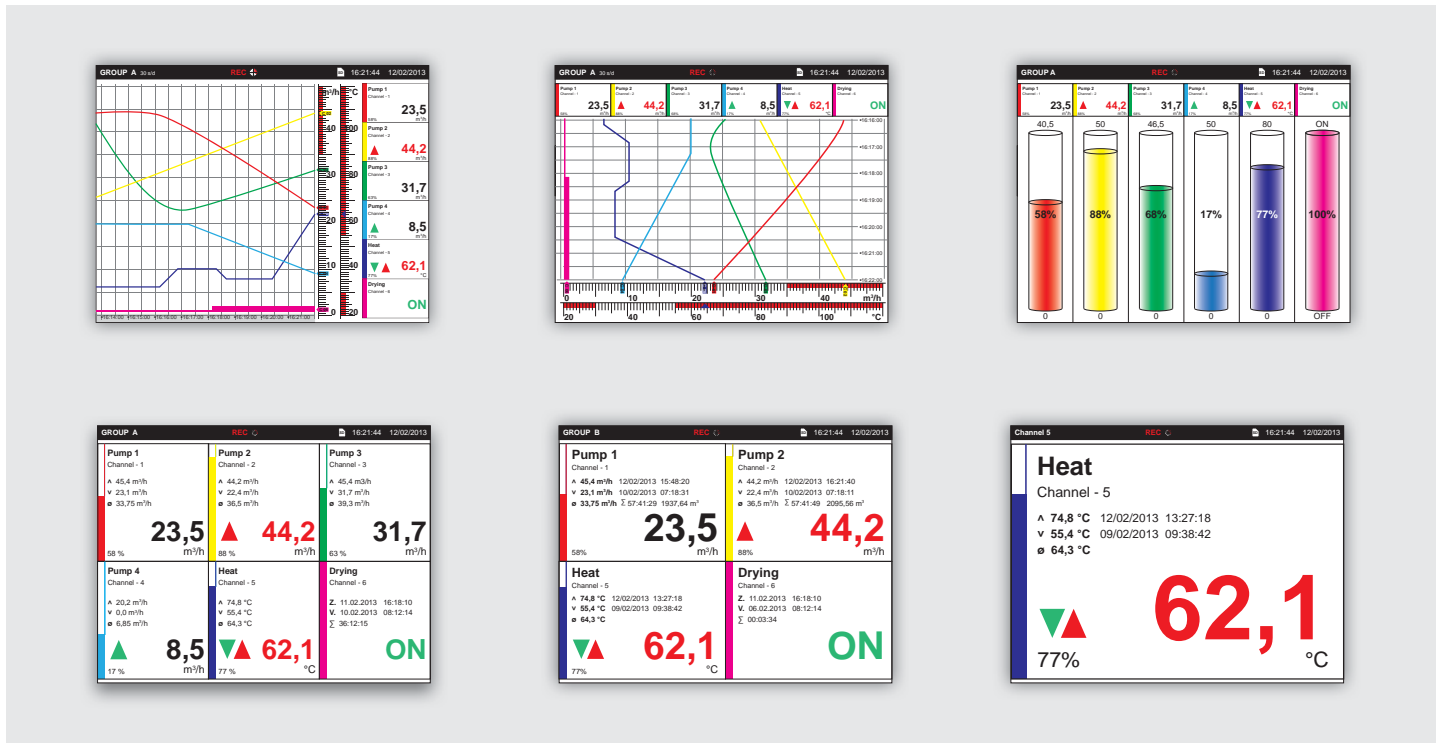

RECORDING OF EVENTS

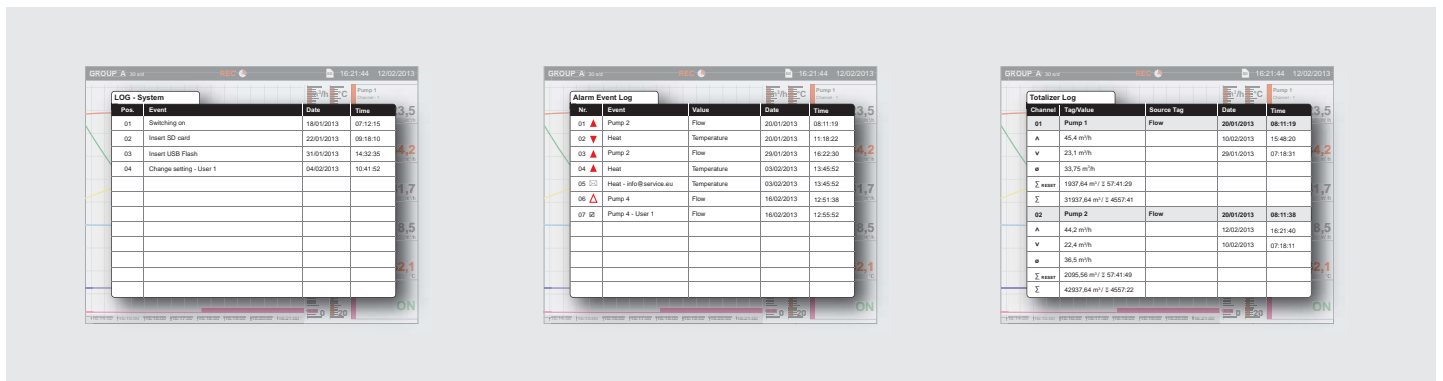

DATA CONNECTION

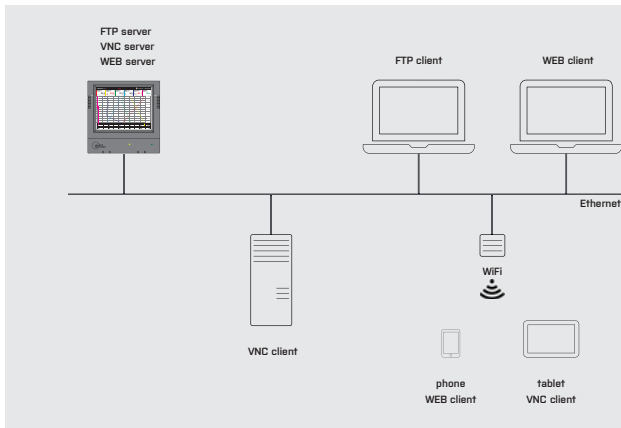

In its basic version the recorder is equipped with connection Ethernet 10/100Base and offers:

- display projection
- transfer of stored data (internal memory, SD card, USB Flash)
- recording of events

Other network function are:

- sending e-mail*
- time synchronization
- DHCP, TCP/IP Modbus (client)

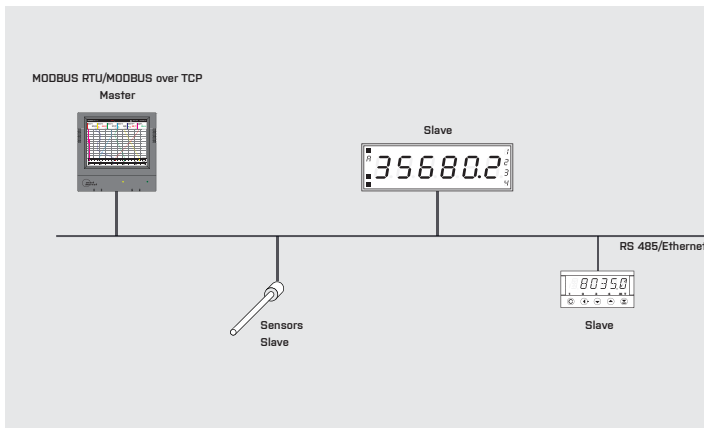

Under preparation is the second version, offering use of data line RS485 with a MODBUS RTU protocol. Up to 247 devices can be connected to the line.

The equipment can be used for:

- collecting additional data not only from OM instruments
- projecting measured or calculated values on an external display, such as e.g. OMD 202RS with up to 125 mm tall digits

When required, two more plug-in cards are available for data communication: PROFIBUS and PROFINET.

Due to the different size of their connectors, these cards have, as the only ones, a set position in slot B5.

...AND ON TOP OF IT

Under the hinged lid, which can be opened by a light pressure upon the blue riders, there is access to control push buttons, microUSB for recorder setting via PC, SD card slot, and USB Flash drive connector.



In the bottom right corner you will find a Stylus for easier control of the recorder

and for display drawings.

Cover of the lid is IP64 so that your recorder, SD card, and USB Flash drive will always stay dry.

If necessary, a seal can be fitted to the hinged lid as a mechanical security against possible accidental opening. Your SD card or USB Flash drive will remain safely stored.



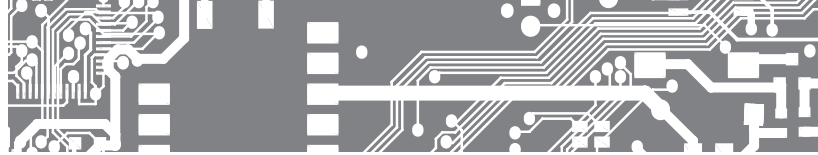

Digital inputs
5x

HTTP/FTP/MODBUS over TCP/email

Ethernet
Standard equipment



IN.1 3x Universal input, isolated
DC: $\pm 60/\pm 150/\pm 300/\pm 1\ 200$ mV
PM: 0...5 mA/0...20 mA/4...20 mA ± 2 V/ ± 5 V/ ± 10 V/ ± 40 V
OHM: 0...100 Ω /0...1/10/100 k Ω /Auto
RTD: Pt 50/100/Pt 500/Pt 1 000
Cu: Cu 50/Cu 100
Ni: Ni 1 000/Ni 10 000
T/C: J/K/T/E/B/S/R/N/L
DU: Linear potentiometer (min. 500 Ω)

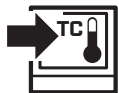
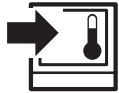

IN.2 4x 0...5/20 mA/4...20 mA,
 $\pm 2/\pm 5/\pm 10/\pm 40$ V, isolated
IN.6 12x 0...5/20 mA/4...20 mA
IN.7 12x $\pm 2/\pm 5/\pm 10/\pm 40$ V
IN.9 3x 0/4...20 mA; $\pm 5/\pm 10$ V, isolated



IN.3 4x input for Pt/Ni/Cu xxxx, isolated
2- and 3-wire connection, isolated
IN.5 5x input for Pt/Ni/Cu xxxx
2- and 3-wire connection

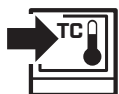

IN.4 4x input for thermocouples, isolated
J/K/T/E/B/S/R/N/L
with cold junction compensation



IN.8 2x input for strain gauges, isolated
range: 1...2/8/16 mV/V
with sensor power supply



IN.10 2x AC/PWR input, isolated
0...450 V/0...5 A
voltage, current, power, frequency



IN.10 8x digital input
12...250 V AC/DC



IN.12 12x counter/frequency
< 10 kHz
IN.13 2x UP/DW counter/frequency/IRC
< 1 MHz

IN

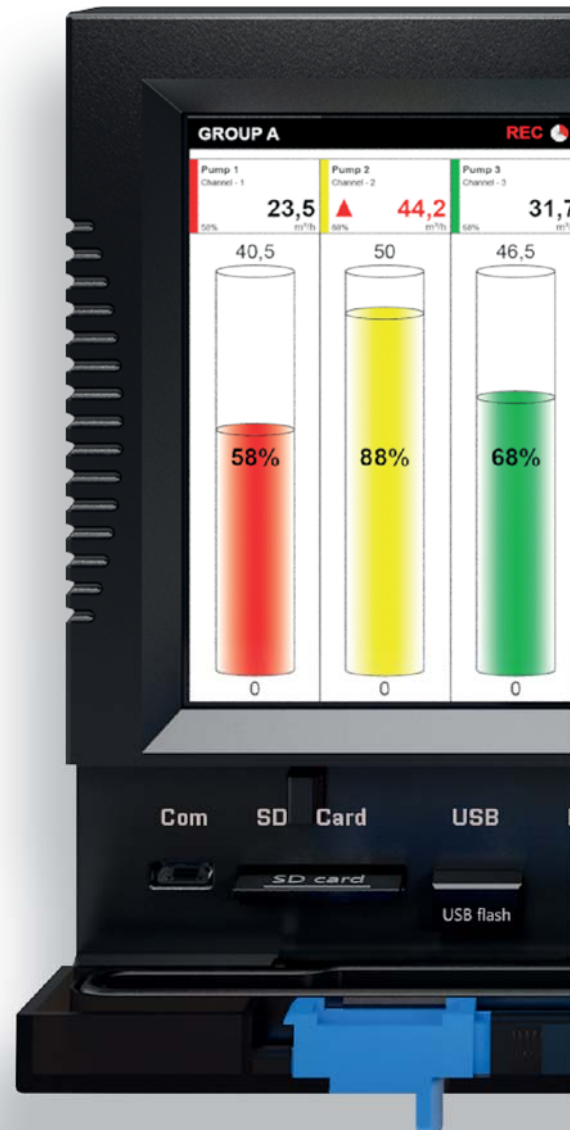

Under the hinged cover are accessible

micro
USB

SD
card
< 32 GB

USB
Type A
flash disc
≤ 32 GB

Digital outputs

2x



RS 485

Standard equipment

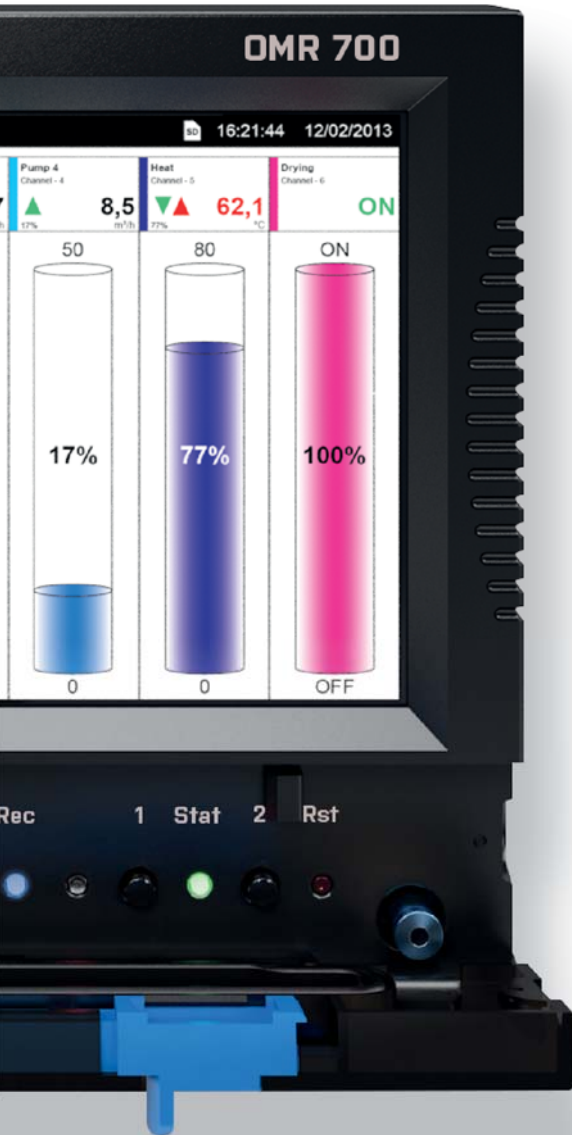

OUT



OUT.1 4x relay with a switch-over contact
OUT.2 8x relay with a switch-on contact



OUT.3 8x open collector, NPN
OUT.4 16x open collector, NPN with common terminal
OUT.5 8x open collector, PNP



OUT.6 6x SSR



AO.1 2x Anal. output, galv. isolated
AO.2 4x Anal. output, galv. isolated



DO.1 1x PROFIBUS



DO.2 1x PROFINET

the following elements and the Stylus

LED

run
error
record

Buttons

menu
record
reset

Stylus



Recorder can hold up to 8 cards in any combination



CONNECTION – INPUT

IN.1 3x Universal input

UNI.1

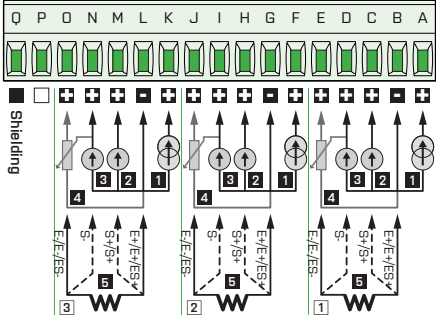

- 1** PM: 0...5/20 mA/4...20 mA
- 2** PM: ± 2 V/ ± 5 V/ ± 10 V/ ± 40 V
- 3** DC: ± 60 / ± 150 / ± 300 / ± 1200 mV
- 4** DU: Lin. potentiometer (> 500 Ω)
- 5** OHM: 0...0.1/1/10/30 k Ω /Auto
- 6** RTD: Pt 50/100/500/1 000
- T/C: J/K/T/E/B/S/R/N/L
- Cu: Cu 50/100
- Ni: Ni 1 000/10 000

IN.4 4x T/C input

IN.4

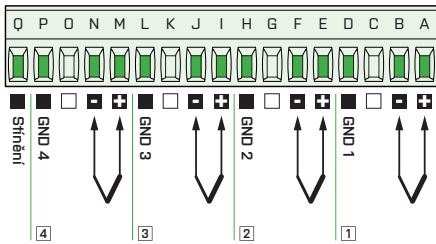

T/C: J/K/T/E/B/S/R/N/L

IN.7 12x DC input, voltage

IN.7

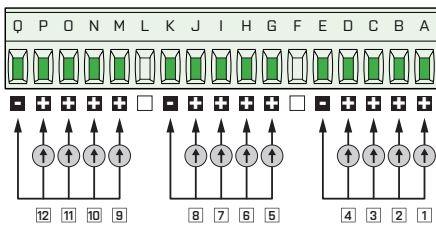

DC - U: ± 2 / ± 5 / ± 10 / 40 V

IN.10 2x AC/PWR input

IN.10

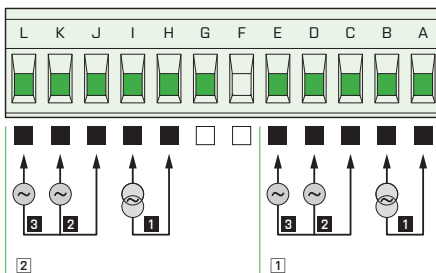

- 1** AC - I: 0...60/150/300 mV
- 2** AC - U1: 0...10/250 V
- 3** AC - U2: 0...120/450 V

IN.2 4x PM input U-I

IN.2

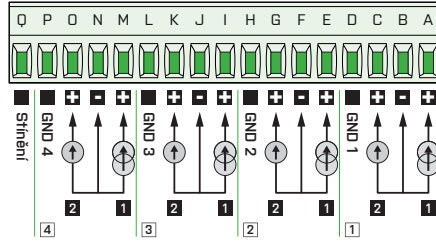

- 1** DC - I: ± 5 / ± 20 mA/4...20 mA
- 2** DC - U: ± 2 / ± 5 / ± 10 / 40 V

IN.5 5x RTD input

IN.5

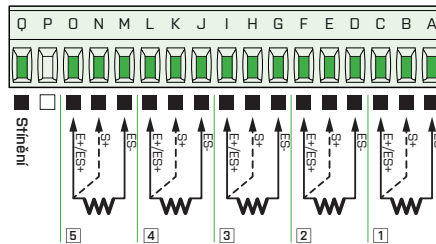

OHM: 0...0.1/1/10/100 k Ω /Auto
RTD: Pt 50/100/500/1 000
Cu: Cu 50/100
Ni: Ni 1 000/10 000

IN.8 2x input for strain gauges

IN.8

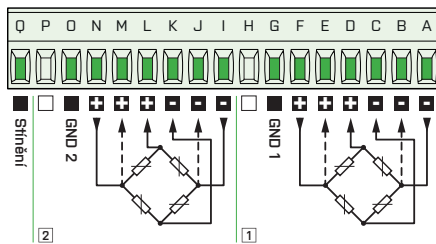

DMS: 1...16 mV/V

IN.11 8x Digital input

IN.11

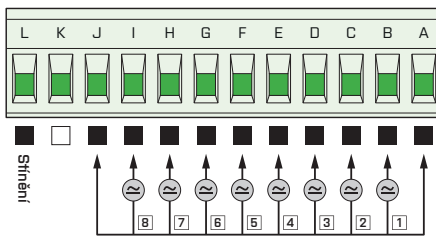

AC/DC: 12...250 V AC/DC

IN.3 4x RTD input

IN.3

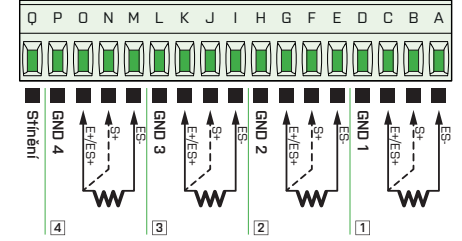

OHM: 0...0.1/1/10/100 k Ω /Auto
RTD: Pt 50/100/500/1 000
Cu: Cu 50/100
Ni: Ni 1 000/10 000

IN.6 12x DC input, current

IN.6

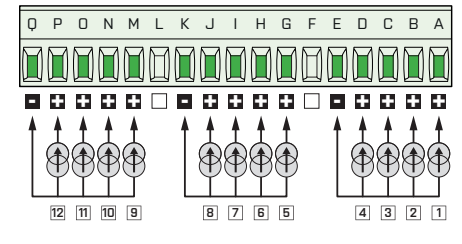

DC - I: ± 5 / ± 20 mA/4...20 mA

IN.9 3x PM input U-I

IN.9

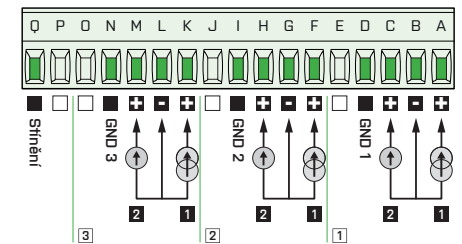

- 1** DC - I: ± 5 / ± 20 mA/4...20 mA
- 2** DC - U: ± 2 / ± 5 / ± 10 / 40 V

IN.12 12x Pulse input

IN.12

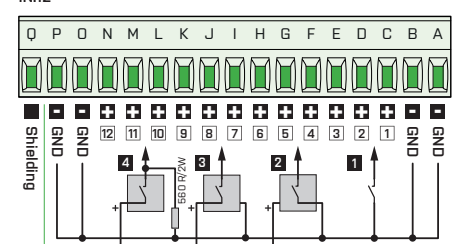

- 1** contact
- 2** 2-wire sensors, PNP NO
- 3** 3-wire sensors, PNP NO
- 4** 3-wire sensors, NPN NO

IN.13 2x Fast pulse input

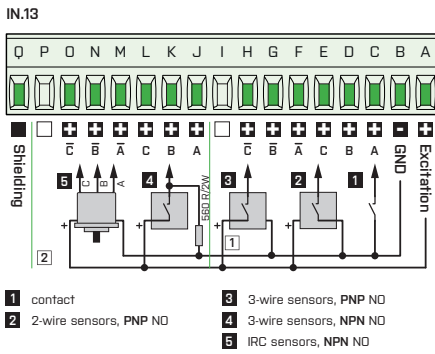

IN.14 2x input for LVDT sensors

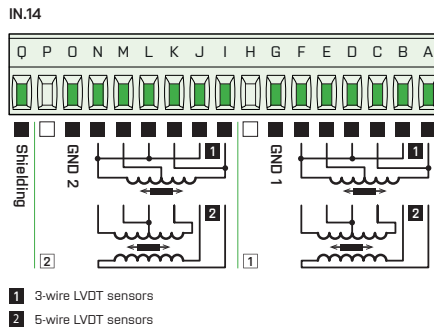

CONNECTION – OUTPUT

OUT.1 4x Relay, switch-over contact

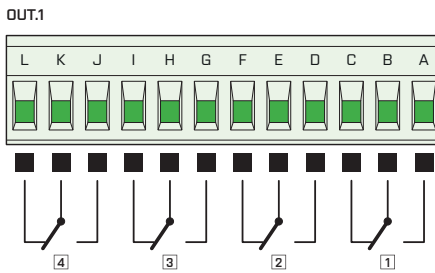

OUT.2 8x Relay, switch-on contact

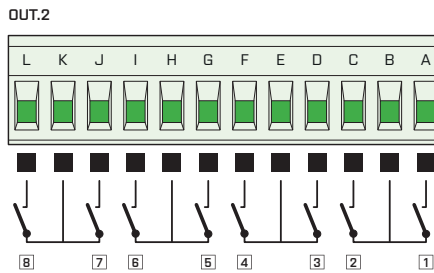

OUT.3 8x OC, NPN

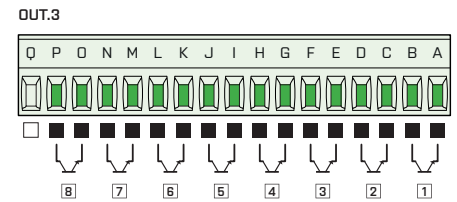

OUT.4 16x OC, NPN

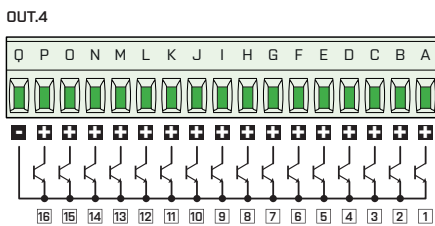

OUT.5 8x OC, PNP

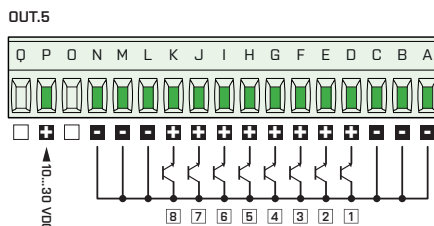

OUT.6 6x SSR

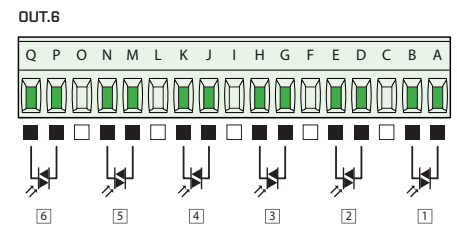

AO.1 2/4x Analogue output

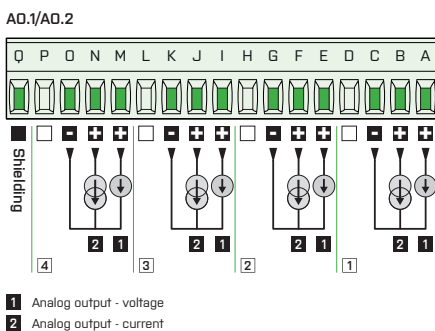

DO.2 1x PROFIBUS

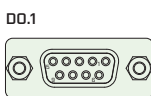

- DO.1**
- Pin assignment
- 3 B: Rx/D/TxD-P data reception/transmission, positive
 - 4 CNTR: signal for repeater control
 - 5 DGND: reference potential for data and +5 V
 - 6 VP: +5 V
 - 8 A: Rx/D/TxD-N data reception/transmission, negative

DO.2 1x PROFINET

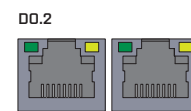

Port 1 Port 2





TECHNICAL DATA

PROJECTION

Display: 5,7" color TFT display with capacitive touch screen
Brightness: adjustable

INSTRUMENT FUNCTIONS

TK: 25 ppm/°C
Accuracy: depending on the measuring card used
Measuring rate: depending on the measuring card used
Accuracy of cold junction measurement: ±1,5°C
Digital inputs: 5x - optional functions
Digital outputs: 2x (open collector) - optional functions
Acoustic signalization: sound module for acoustic signalization with 1,5 W loud speaker
Value recording:
 - into instrument memory (512 MB) with 4 fold compression
 - USB FLASH with support of FAT32 up to 32 GB
 - SD card with support of FAT32 up to 32 GB
RTC: 15 ppm/°C, time-date-value channel/display/nod
Watch-dog: reset after 500 ms
Calibration: at 25°C and 40% of r.h.

COMMUNICATION

Protocols: ASCII, MODBUS RTU, FTP, SMPT
Data format: 8 bits + without parity + 1 stop bit (ASCII)
Rate: 300...230 400 Baud
RS 485: isolated, addressing (max. 31 instruments)
Ethernet: 10/100BaseT, secure communication, SMPT, FTP, TCP/IP Modbus
Wi-Fi: optional module with standard or industrial temperature range

POWER SUPPLY

Range: 10...30 V AC/DC, ±10%, PF ≥ 0,4, I_{STP} < 75 A/2 ms
 80...250 V AC/DC, ±10%, PF ≥ 0,4, I_{STP} < 45 A/2 ms
Consumption: < 30 VA / < 30 W
Power supply is protected by a fuse inside the instrument.

MECHANIC PROPERTIES

Material: Noryl GFN2 SE1, non-flammable UL 94 V-1
Dimensions: 150 x 150 x 80 mm
Depth behind panel: 85 mm
Panel cut-out: 138 x 138 mm
Securing lid: the front lid can be sealed

OPERATING CONDITIONS

Connection: connector terminal board, conductor cross-section < 1,5/2,5 mm²
Stabilisation period: within 15 minutes after switch-on
Working temperature: -20°...60°C
Storage temperature: -20°...85°C
Cover: IP64 (front panel only)
Overvoltage category: EN 61010-1, A2
Dielectric strength: 4 kVAC after 1 min. between power supply and input
 4 kVAC after 1 min. betw. power supply and data/anal. output
 4 kVAC after 1 min. between input and relay output
 2,5 kVAC after 1 min. between input and data/anal. output
Insulation resistance: for pollution degree II, measurement category III.
 Instrument power supply > 670 V (ZI), 300 V (DI)
 Input, output, PN > 300 V (ZI), 150 V (DI)
EMC: EN 61326-1

PI - Primary insulation, DI - Double insulation

CONNECTOR LAYOUT

Power source
 Firmly placed card



A4: Card slot



A3: Card slot



A2: Card slot



A1: Card slot

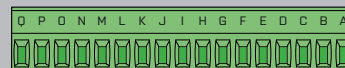

B5: Card slot



B4: Card slot



B3: Card slot

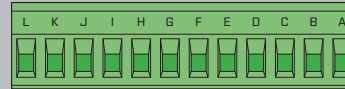

B2: Card slot



Communication
 Firmly placed card

Digital inputs

Ethernet

RS 485 CANbus

Digital outputs

Slots A are designated for fast analogue cards, slot B5 is designated for cards DO.1/2. There are no restrictions for placement of other cards.

ORDER CODE

OMR 700

- - -

Power source	10...30 V AC/DC, isolated	0																		
	80...250 V AC/DC, isolated	1																		
Wi-Fi module	no		0																	
	yes, standard temper. range		1																	
	yes, industrial temper. range		2																	
Features, see table „Card types“																				
Here list the selected cards																				
Specification	customer version, do not fill in																			00

Card types

Order code	Designation	Description	Range	Accuracy (of range)	Transmitter (resolution)	Rate (meas./s)	Isolated channels
0	PW.0	Power supply	10...30 V AC/DC				yes
1	PW.1	Power supply	80...250 V AC/DC				yes
A	IN.1	3x Universal input	DC: $\pm 60/\pm 150/\pm 300/\pm 1\ 200$ mV PM: 0...5 mA/0...20 mA/4...20 mA/ ± 2 V/ ± 5 V/ ± 10 V/ ± 40 V OHM: 0...100 Ω /0...1 k Ω /0...10 k Ω /0...30 k Ω RTD: Pt 50/100/Pt 500/Pt 1 000 Cu: Cu 50/Cu 100 Ni: Ni 1 000/Ni 10 000 T/C: J/K/T/E/B/S/R/N/L DU: Linear potentiometer [min. 500 Ω]	$\pm 0,15\%$	24 bits	< 40	yes
B	IN.2	4x power/voltage input	0...5 mA/0...20 mA/4...20 mA/ ± 2 V/ ± 5 V/ ± 10 V/ ± 40 V	$\pm 0,2$	16 bits	< 1 000	yes
C	IN.3	4x RTD	Pt 50/100/1000, Ni 1000/10 000, Cu 50/100	$\pm 0,2$	16 bits	< 1 000	yes
D	IN.4	4x T/C	J/K/T/E/B/S/R/N/L	$\pm 0,2$	16 bits	< 500	yes
E	IN.5	5x RTD	Pt 50/100/1000, Ni 1000/10 000, Cu 50/100	$\pm 0,2$	16 bits	< 500	no
F	IN.6	12x power input	± 5 mA/ ± 20 mA/4...20 mA	$\pm 0,2$	16 bits	< 1 000	no
G	IN.7	12x voltage input	± 2 V/ ± 5 V/ ± 10 V/ ± 40 V	$\pm 0,2$	16 bits	< 1 000	no
H	IN.8	2x input for strain gauges with pow. supply	1...16 mV/V	$\pm 0,02$	24 bits	< 1 000	yes
I	IN.9	3x precise power/voltage input	0/4...20 mA, $\pm 5/\pm 10$ V	$\pm 0,02$	24 bits	< 1 000	yes
J	IN.10	2x voltage [V_{RMS}], power [A_{RMS}], freq. [Hz] with calculation of Q, S, cos fi	input U: 0...10 V/0...120 V/0...250 V/0...450 V input I: 0...60 mV/0...150 mV/0...300 mV/0...1 A/0...2,5 A/0...5 A	$\pm 0,3\%$		< 10	yes
K	IN.11	8x analogue/digital input	12...250 V AC/DC			< 1 ms	no
L	IN.12	12x counter/frequency	0...30 V, PNP/NPN/contact, adjustable comparison levels, input frequency 0,1 Hz...10 kHz				no
M	IN.13	2x UP/D, IRC with power supply	5/24 V, TTL/Line, adjustable comparison levels, input frequency 0,1 Hz...1 MHz				no
N	IN.14	2x input for LVDT sensors	3/5/6-wire connection, 1/3/5 VAC with frequency 2,5/5/10 kHz	$\pm 0,02$	24 bits	< 1 000	yes
P	OUT.1	4x relay with switch-over contact	250 VAC/30 VDC, 3 A			< 10 ms	
Q	OUT.2	8x relay with switch-on contact	250 VAC/30 VDC, 3 A			< 10 ms	
R	OUT.3	8x open collector, NPN	30 VDC/100 mA			< 0,2 ms	
S	OUT.4	16x open collector, NPN common terminal	30 VDC/100 mA			< 0,2 ms	
T	OUT.5	8x open collector, PNP	30 VDC/700 mA			< 0,2 ms	
U	OUT.6	6x SSR	250 VAC, 1 A			< 0,2 ms	
V	AO.1	2x Analogue output	0...2/5/10 V, ± 10 V, 0...5 mA, 0/4...20 mA [comp. < 600 Ω /12 V]	$\pm 0,1\%$		< 1 ms	yes
W	AO.2	4x Analogue output	0...2/5/10 V, ± 10 V, 0...5 mA, 0/4...20 mA [comp. < 600 Ω /12 V]	$\pm 0,1\%$		< 1 ms	yes
Y	DO.1	PROFIBUS					
Z	DO.2	PROFINET					

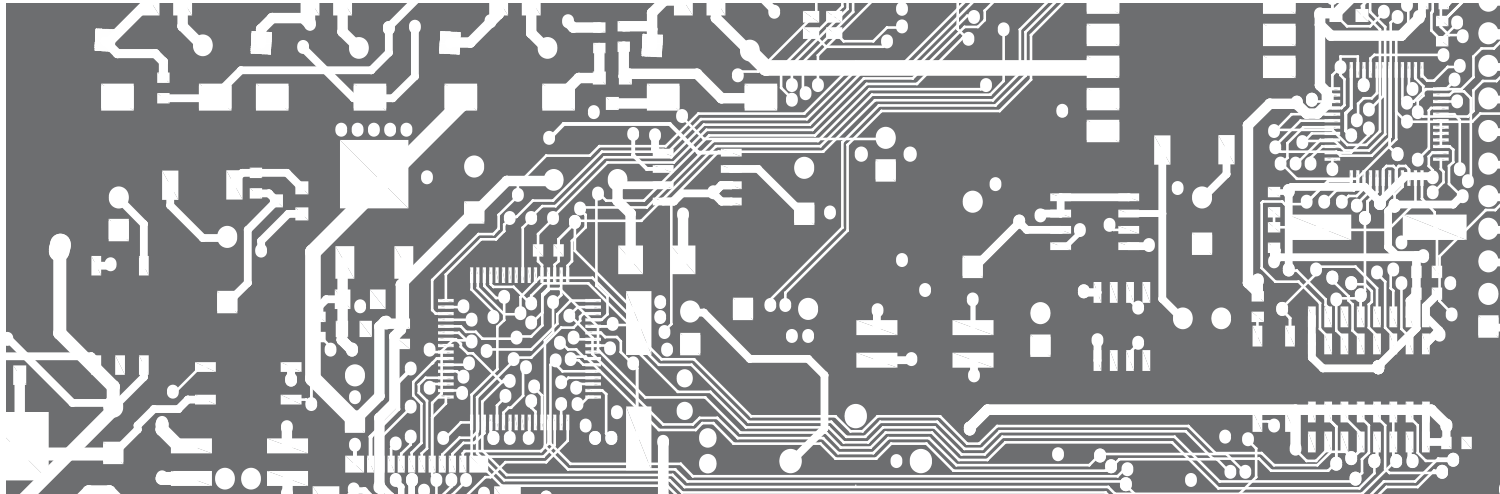

© ORBIT MERRET - OMR 700 - 2016.2 - en

ORBIT MERRET, spol. s r. o.

Vodňanská 675/30
198 00 Prague 9
Czech Republic

phone.: +420 281 040 200
fax.: +420 281 040 299
e-mail: orbit@merret.eu

www.orbit.merret.eu

FOREIGN PARTNERS

Australia
AUTOTECH Control
www.autechcontrol.com.au

Austria
GRUBER ELECTRIC GmbH
www.gruber-electric.at

Belgium
INELMATEC
www.inelmatec.be

Bosnia and Herzegovina
Instruments Ltd.
www.instruments.ba

Canada
A-Tech Instruments Ltd.
www.a-tech.ca

China
Shanghai Sibo MGE Co., Ltd.
www.sentop.com

Egypt
El-Gammal Industrial Systems Co.
www.elgammalgroup-eg.com

Estonia
MTR Automation OU
www.mtr.ee

Finland
Aseko
www.aseko.fi

France
ADEL Instrumentation
www.adel-instrumentation.fr

Germany
VARIOHM- EUROSENSORS Ltd.
www.variohm.com

Great Britain
VARIOHM- EUROSENSORS Ltd.
www.variohm.com

Hungary
Q-TECH Engineering Ltd and Co.
www.q-tech.hu

Italy
ASIT G.E Global Engineering
www.asit-ge.com

Iran
SegalTech
www.segaltech.com

Israel
ELCON
www.elcon.co.il

Korea
SUNDEN
www.sunden.co.kr

Kuwait
KCC Engineering & Contracting Co.
www.kccecc.com.kw

Lithuania
AXIS Industries
www.axis.lt

Netherlands
AE Sensors B.V.
www.aesensors.nl

New Zealand
Carrel-Electrade
www.carrel-electrade.co.nz

Philippines
WEST POINT ENGINEERING SUPPLIES
www.westpointengineeringsupplies.com.ph

Poland
TR Automatyka Sp.z o.o.
www.trautomatyka.pl

Portugal
Zeben – Sistemas Electrónicos Lda.
www.zeben.pt

Romania
Synchro Comp s.r.l.
www.synchro.ro

Russia
ODD „ORBIT MERRET”
www.orbit.merret.ru

Saudi Arabia
SETRA
www.setra.com.sa

Slovakia
TECHREG, spol. s r. o.
www.techreg.sk

Spain
Ingenieros Asociados de Control S.L.
www.iac-sles

Sweden
Thermokon - Danelko
www.danelko.se

Switzerland
MICRONOR AG
www.micronor.ch

Thailand
Lamax and Partners Co.,Ltd.
www.lamax.co.th

Tunisia
Compagnie Générale Du Matériel - CGM

Turkey
ILKE
www.ilkeotomasyon.com.tr

Ukraine
SEA Company
www.sea.com.ua

USA
Bristol Instruments
www.bristolinstruments.com

ORBIT MERRET, spol. s r. o.
holds the following certificates:



ORBIT MERRET, spol. s r. o. represents
in the Czech Republic and in Slovakia the following companies:



novotechnik
Siedle Group

celesco

TECFLOW
INTERNATIONAL

CONTELEC